

DESIGNED	DRAWN	CHECKED 3	CHECKED 2	CHECKED 1	APPROVED
Surface roughness(Ra)					
12.5μ (▽, equivalent to 12.5)					
3.2μ (▽, equivalent to 3.2)					
0.8μ (▽, equivalent to 0.8)					
0.2μ (▽, equivalent to 0.2)					
Grade of screw thread : JIS Grade 2					
Revision					

	Port name	Port size	On delivery	Tightening torque N _m (lbf·ft)
A	Delivery port	SAE J518C High pressure (Code 62) 1 1/4"	Covered with tape	157 (115.8)
B	Suction port	SAE J518C Std. pressure (Code 61) 2 1/2"	Covered with tape	98 (72.3)
Dr	Drain port	SAE J1926/1 Straight thread O-Ring boss 3/4" O. D Tube 1 1/16-12UN-2B	Attached with steel plug	167 (123.2)
PL	Load sensing port (Type LO, LI)	SAE J1926/1 Straight thread O-Ring boss 1/4" O. D Tube 7/16-20UNF-2B	Attached with steel plug	12 (8.8)
Pc	Pressure control port (Type PO)	SAE J1926/1 Straight thread O-Ring boss 1/4" O. D Tube 7/16-20UNF-2B	Attached with steel plug	12 (8.8)
Tair	Air bleeder port	SAE J1926/1 Straight thread O-Ring boss 1/4" O. D Tube 7/16-20UNF-2B	Attached with steel plug	12 (8.8)

Operating specifications

Displacement	cm ³ (in ³)	112 (6.83)
Max. self priming speed	min ⁻¹	2200 (Clockwise viewed from shaft end)
Rated pressure	bar (psi)	320 (4600)
Peak pressure	bar (psi)	350 (5000)
Pump model name		K3VL112/B-1 _N ^{SS} R _{KM} -LO PO LI

Notes on mounting and operation

- The pump shaft and flange surfaces should be cleaned. Remove an anti-rust material.
- Do not apply any form of axial loading to the pump shaft.
- The uppermost drain port should be used and the drain piping should be so connected as to keep the casing filled with oil.
- Keep the casing pressure below 1 bar (14 psi) normally, and below 4 bar (58 psi) at its peak.
- Make sure the drain piping led into the oil tank is kept below the surface of the oil (to prevent aeration).
- Make sure the suction pressure in the suction flange is kept above 0 bar (0 psi) normally.
- Mineral antiwear type hydraulic oil should be used.
- For satisfactory service life of the pump in application, the operating fluid should be continuously filtered to a minimum cleanliness level of NAS1638 class 9 or 18/15 to ISO/DIS 4406.
- Provide a 150 mesh (100μm) strainer in the suction line.
- Install a 10μm filter in the return line.
- Allowable oil temperature range : -20~95°.
- Oil viscosity range : 10~1000cSt when 200~1000cSt, take warming up before real working.
- Caution for the vertical mounting.

The oil level in the tank should be upper than the pump mounting flange. (fig. 1)
if the oil level is lower than the pump level, forced lubrication should be made from the air bleeder port. (flow 1~2 l/min)

(a) Installation within a tank

- Open the drain port and the air bleeder port.

(b) Installation outside a tank (fig. 2)

- Pipe the drain port and the air bleeder port to tank.
- If the pipe for draining or air bleeding is upper than the oil level, it should be filled with oil before starting the pump.

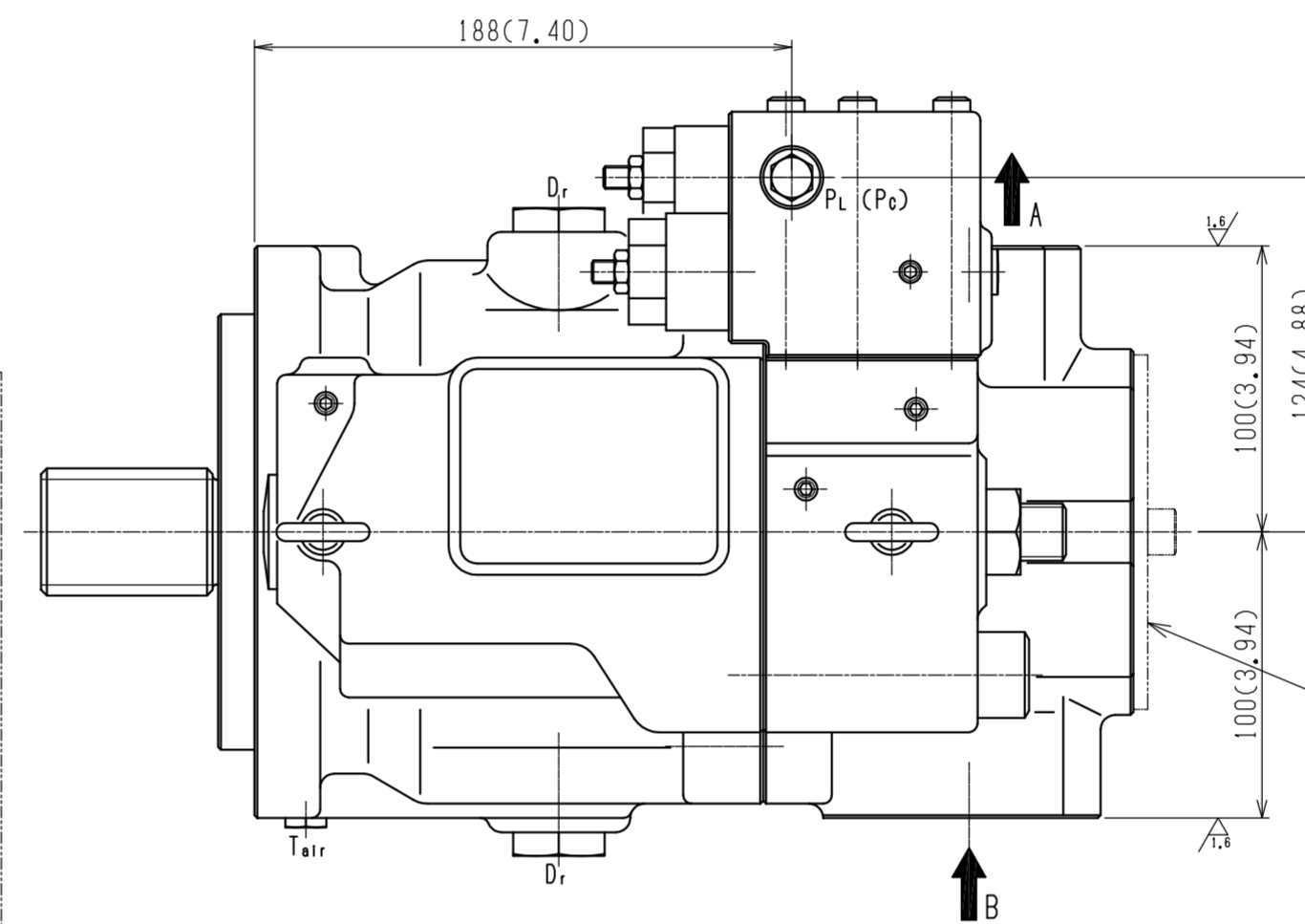
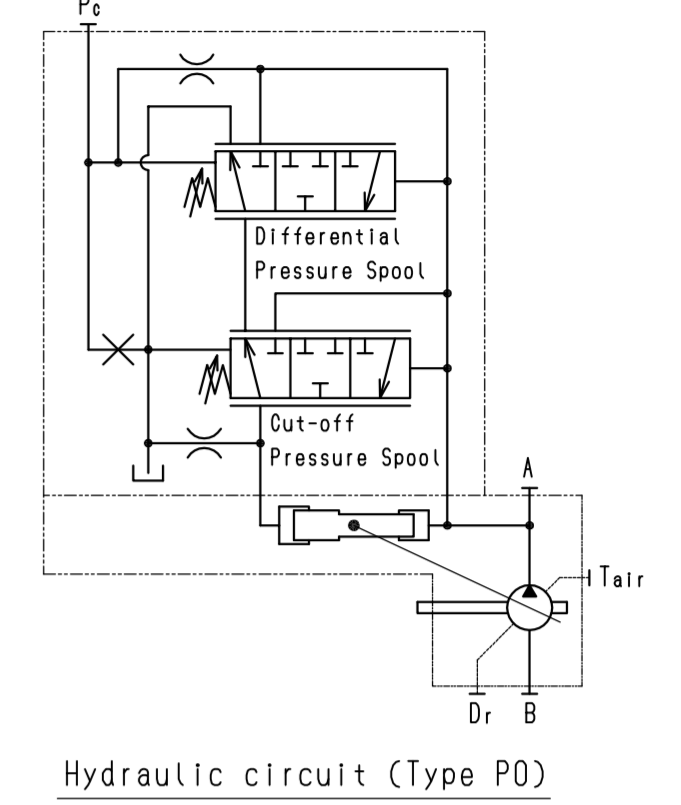
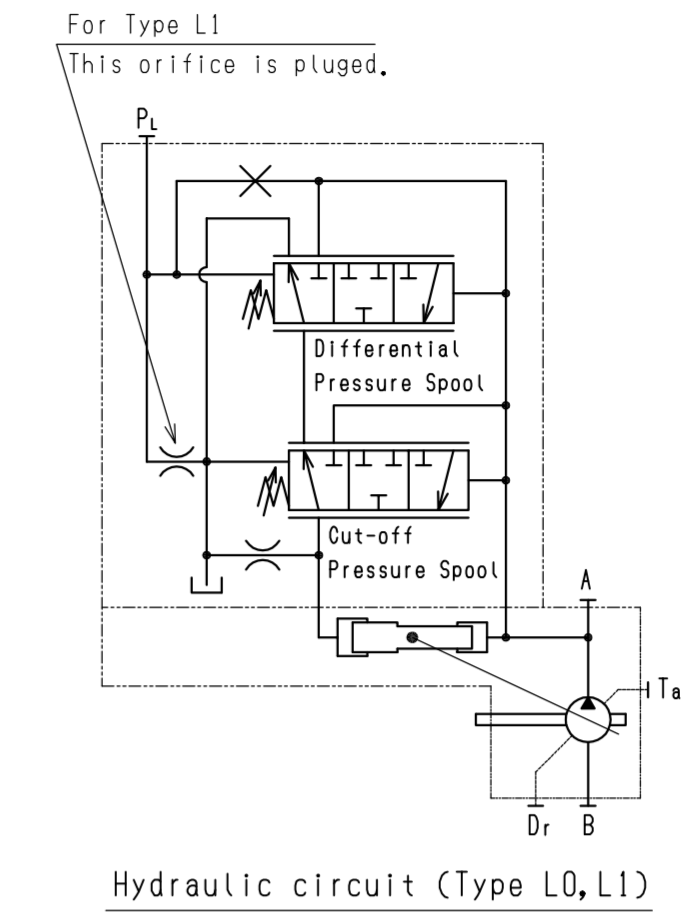
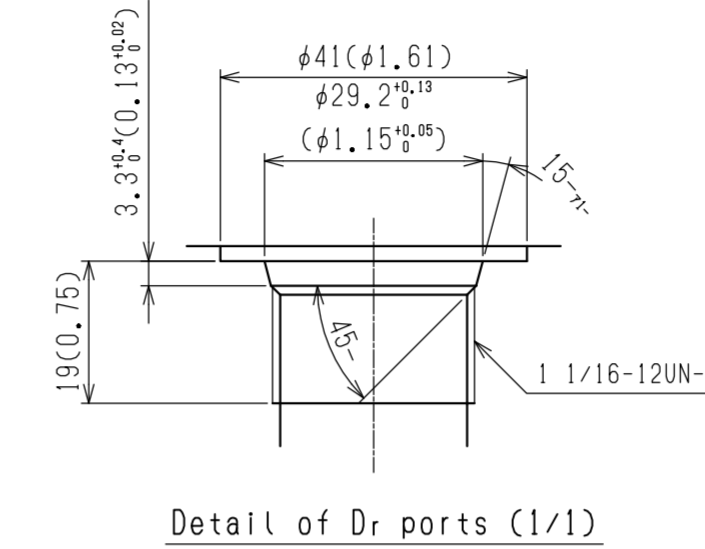
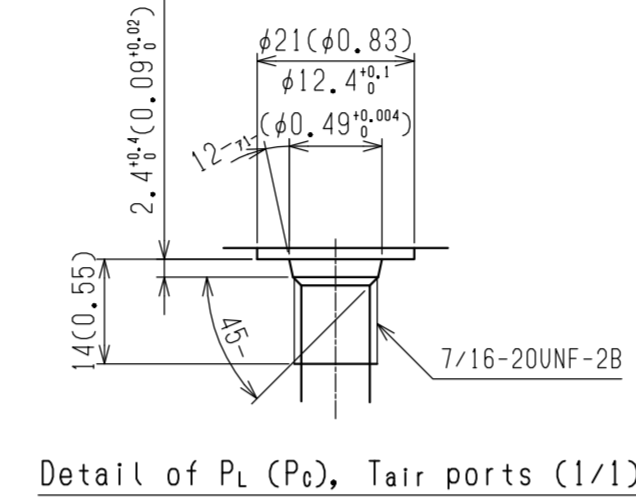
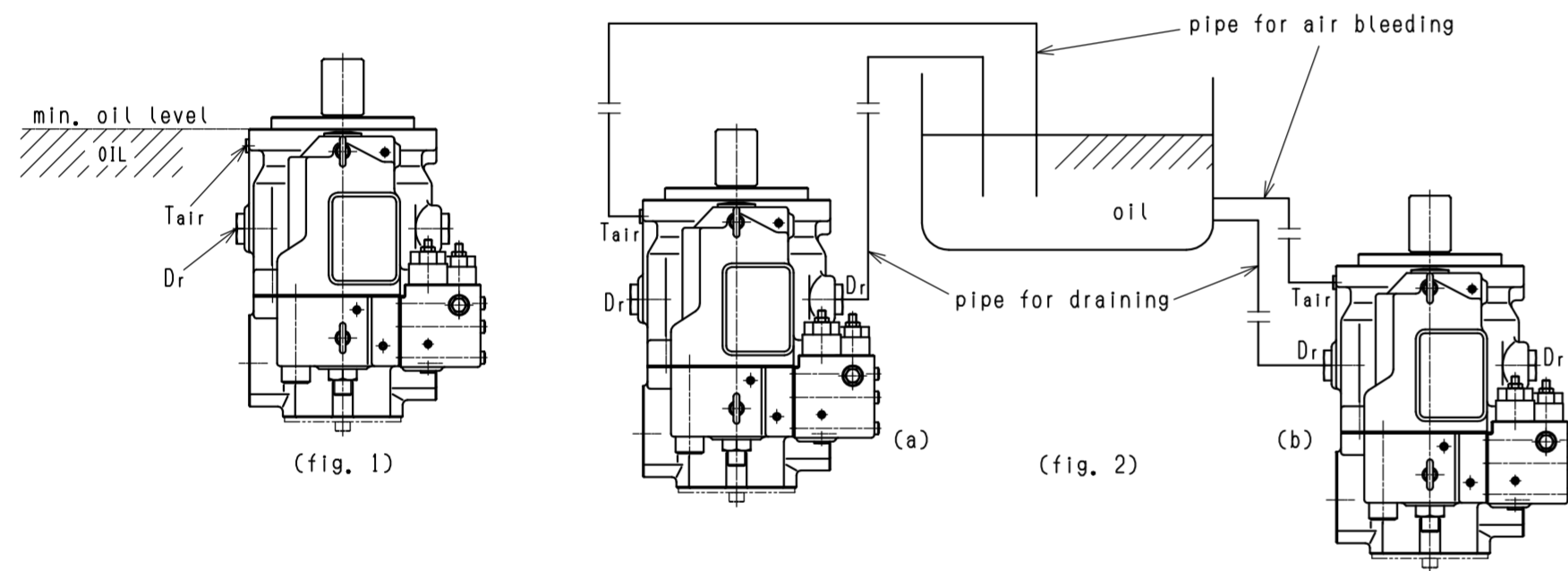

In case of K3VL112/B-1_N^{SS} R_{KM} -LO PO LI
Steel cover, O-ring and Bolts are attached

In case of K3VL112/B-1_N^{SS} R_{KM} -LO PO LI
Covered with tape

Pump model name	K3VL112/B
Adjustable range of max. displacement	cm ³ 56~112
L	mm 3.8~16

Max. flow adjusting screw
Approx. displacement change per revolution of screw : 11.5cm³

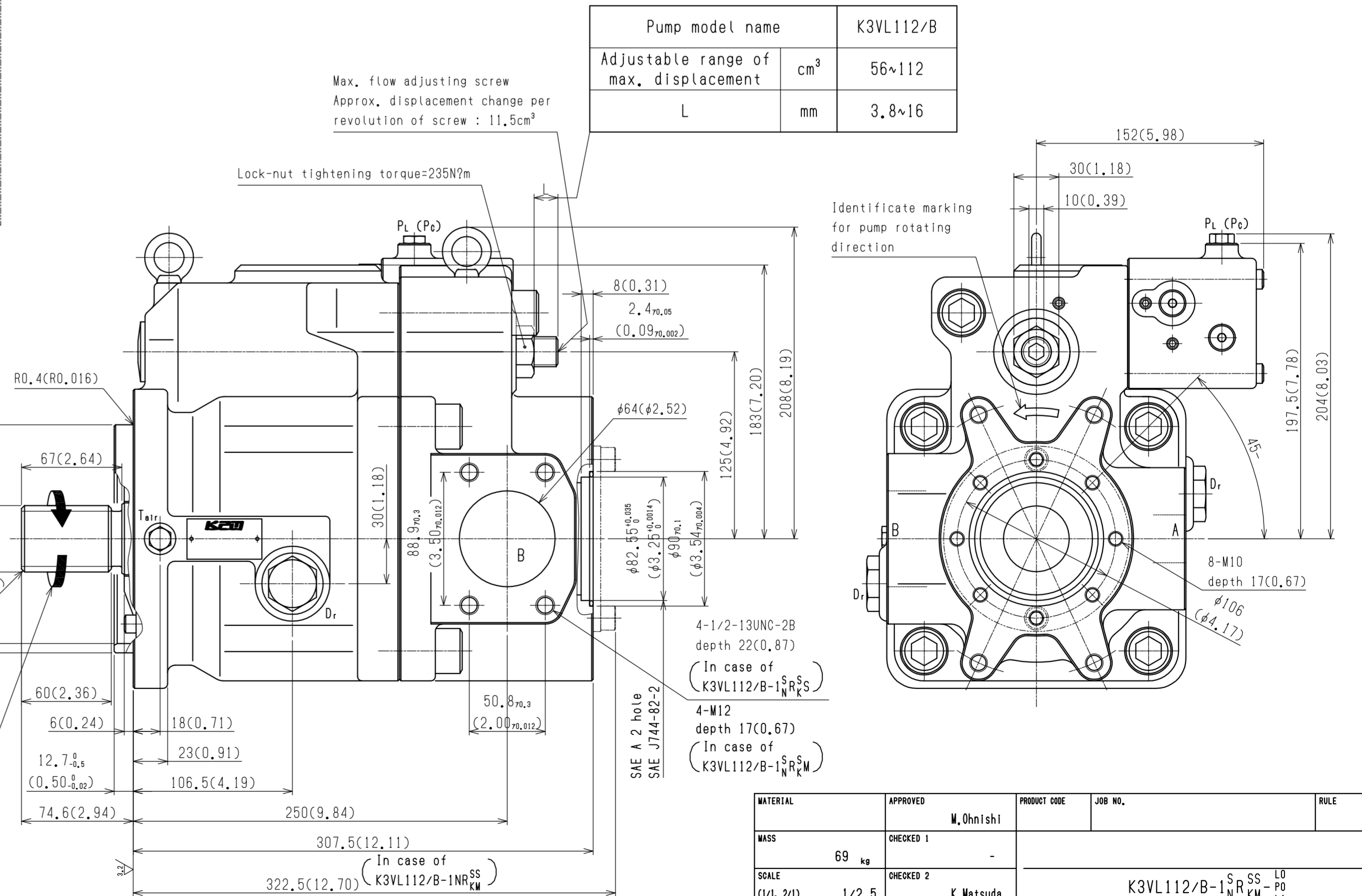
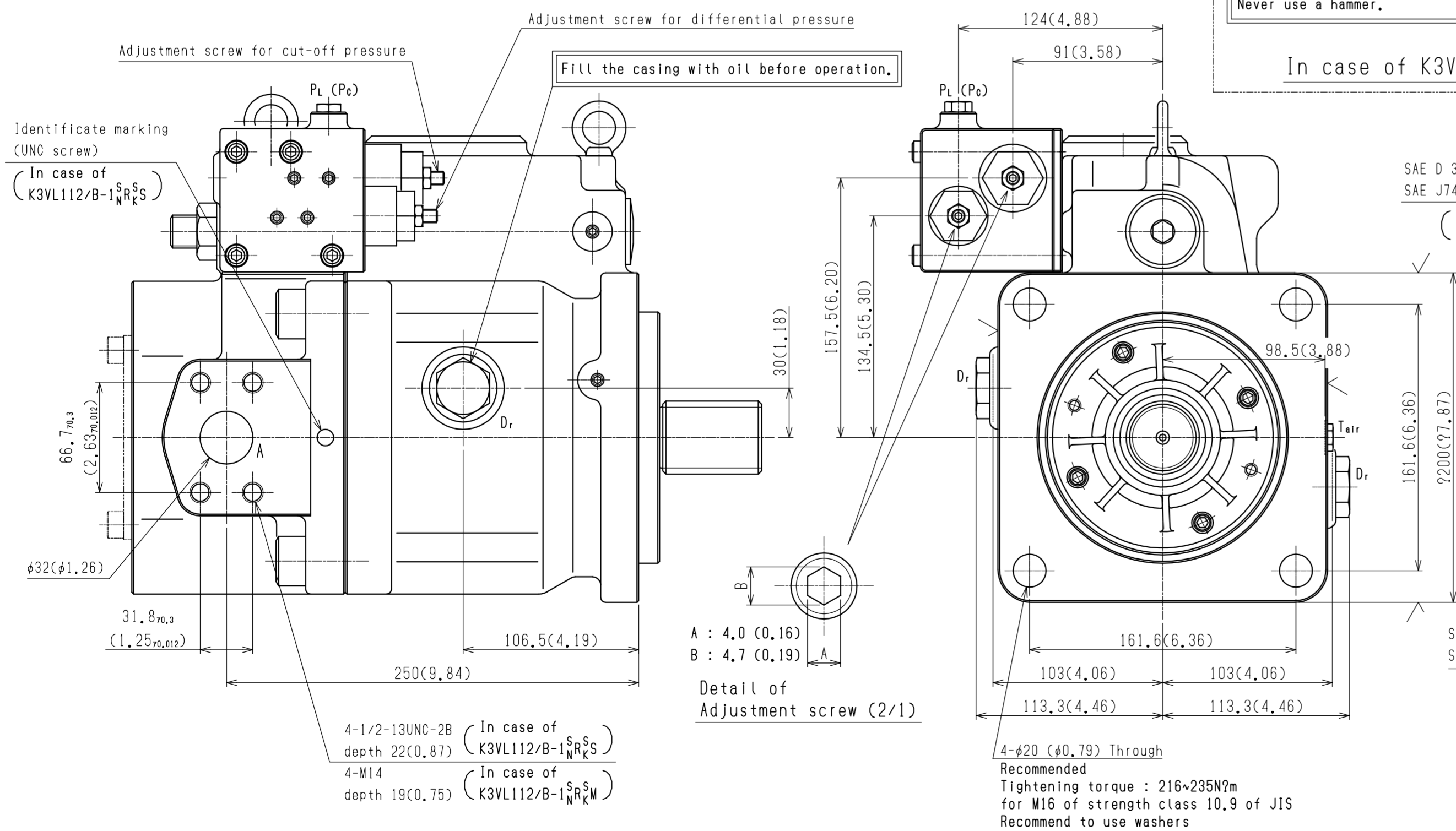
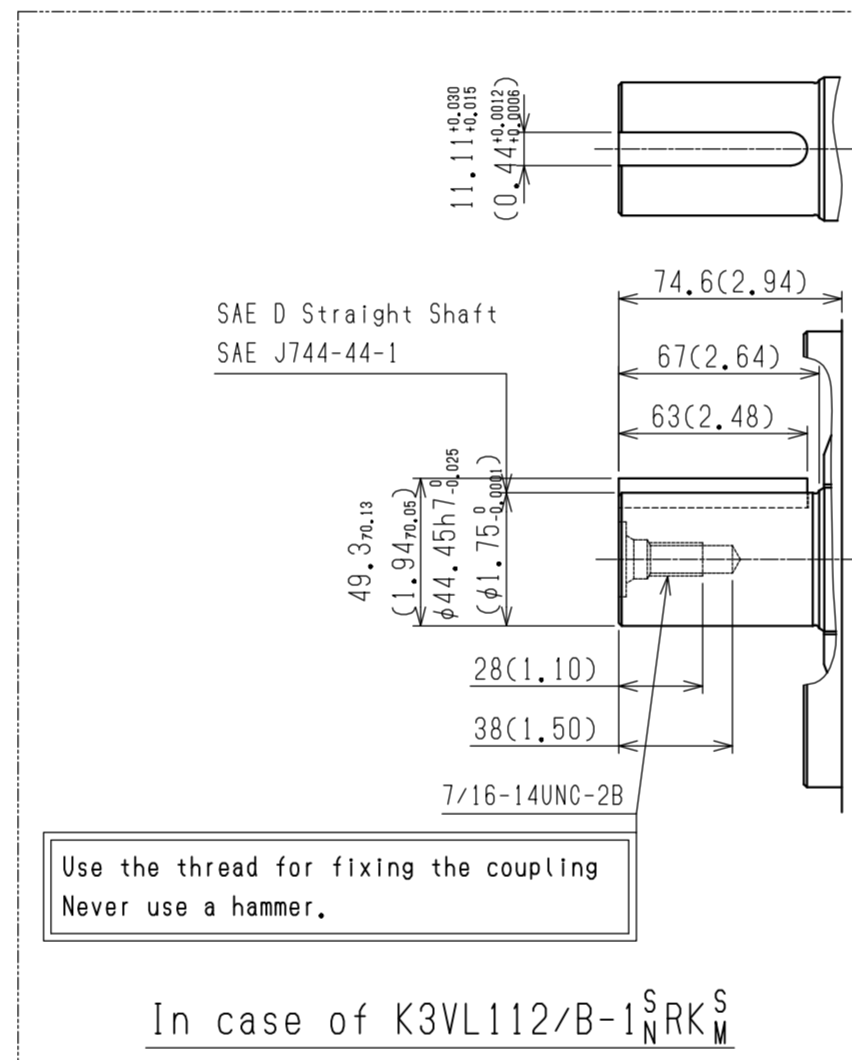

MATERIAL	APPROVED	PRODUCT CODE	JOB NO.	ROLE
MASS 69 kg	CHECKED 1 W. Ohnishi			
SCALE (1/1, 2/1) 1/2.5	CHECKED 2 K. Matsuda	K3VL112/B-1 _N ^{SS} R _{KM} -LO PO LI		
3 RD ANGLE PROJECTION	CHECKED 3 I. Yoshimura	INSTALLATION DIMENSIONS		
DATE Feb. ++, 2005	DRAWN N. Yanamoto	PART NO.	DWG. NO. 02430-4440	SPARE TOTAL